

It has been a year since I specified the size of the puzzle backlogs I have on hand. Currently, I have a comfortable supply of regular and game (bridge, chess, etc.) problems, but I could use a few more speed problems.

PROBLEMS

M/J 1. Jorgen Harmse wants you to suppose that White has a forced mate (possibly exceeding the 50-move rule or other limits, but with no opportunity for Black to arrange a stalemate or to checkmate White) and plays to minimize the number of moves. How many times can the same position (arrangement of pieces on the board) conceivably occur? You need not show that an actual game can give rise to this scenario.

M/J 2. Rocco Giovanniello has four balls: one of radius 1, the second of radius 2, the third of radius 3, and the fourth of radius 4. The three largest balls are resting on a level surface and are tangent to each other. Now place the smallest ball in the crater between the other three. How far is this ball off the ground?

M/J 3. The MIT logo reminds David Hagen of a Rubik's Cube with recolored faces. However, his cube has been scrambled. He asks you to restore the logo in the minimum number of steps. The original cube and the desired result are below (the *I* in MIT is lowercase gray).

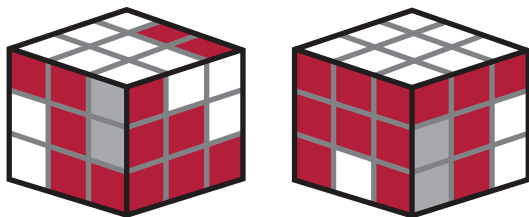

All unseen faces (the faces away from you) are white. This is a mental exercise. You should not have to resticker your Rubik's Cube to solve this problem.

SPEED DEPARTMENT

On a 12-hour clock, how many seconds does it take the hour hand to traverse one minute of arc?

SOLUTIONS

J/F 1. For a little variety, Eugene Sard offers us a different kind of bridge problem. "Five bridge players, A, B, C, D, and E, want to rotate partnerships with A out first, B out second, etc., until E is out last, so that no partnership is repeated. This must be a common problem that many players have presumably worked out

before, but the question here is how many solutions exist, and what they are."

The following solution is from Stephen Scheinberg.

With players A, B, C, D, and E, the 10 possible partnerships are (obviously) AB, AC, AD, AE, BC, BD, BE, CD, CE, and DE. If hand one has A sitting out, hand two has B sitting out, etc., here are the possibilities for seatings in each of the five hands.

Player sitting out	Possible seatings
A	BC+DE, BD+CE, BE+CD
B	AC+DE, AD+CE, AE+CD
C	AB+DE, AD+BE, AE+BD
D	AB+CE, AC+BE, AE+BC
E	AB+CD, AC+BD, AD+BC

For the first hand, with A out, there are three possible seatings, each identifiable uniquely by the partner to B (for example, if B partners with C, then D and E must be the opposing partnership).

Given any one of these, there are two possible seatings for the second hand. The first two hands could be BC+DE, AD+CE or BC+DE, AE+CD.

The sequence BC+DE, AC+DE cannot be used, since DE is repeated.

Now, for each of these, the remaining seatings are determined. For example: given BC+DE for the first hand (A out) and AE+CD for the second hand (B out), when C is out we cannot have AB+DE (because DE has appeared in hand one), nor AE+BD (because AE has appeared in hand two); only AB+BE is allowed. Then in hand four, AC+BD is the only possible seating under the conditions; and in hand five, AC+BD is the only one allowed.

A similar analysis applies to each of the other five possible arrangements for hands one and two. And with one exception (BE+CD followed by AD+CE), there is only one third hand possible, and one fourth and one fifth. In the case of the exception, there are two possible seatings for the third hand; however, only one has allowable seatings for hands four and five. (See below.) The list of all possible sequences of seatings is this:

BC+DE	AD+CE	AE+BD	AC+BE	AB+CD
BC+DE	AE+CD	AD+BE	AB+CE	AC+BD
BD+CE	AC+DE	AD+BE	AE+BC	AB+CD
BD+CE	AE+CD	AB+DE	AC+BE	AD+BC
BE+CD	AC+DE	AE+BD	AB+CE	AD+BC
BE+CD	AD+CE	AB+DE	AE+BC	AC+BD
["	"	AE+BD	!none
]				

The sequence BE+CD, AD+CE can have two (!) possible third-hand seatings; however, for the sequence BE+CD, AD+CE, AE+BD, no fourth hand fits the criteria.

J/F 2. William Tucker's goal in life (I suppose) is to solve every possible crossword puzzle. Step one is to determine how many there are. He is looking for 15-by-15 grids of "open" and "blacked-out" squares obeying the standard 180° rotational symmetry, with no words of length one or two (all open squares are contained in a row or column of at least three open squares). No row or column can be completely blacked out.

Although several readers commented favorably on this problem, only Tom Terwilliger submitted a solution. He writes that this was the most interesting puzzle he had seen in several months: "I just wasted [I would prefer 'spent'—Ed.] much of the past five days on it!"

Alas, he also reports that his computer system is not nearly powerful enough to solve the full 15-by-15 problem, despite his having improved the program to reduce the execution time by a factor of 20. For sizes 13, 14, and 15, Terwilliger has only estimates extrapolated from the answers obtained for smaller sizes. He has supplied the following table (with some rounding by the editor).

Size	Across	Symmetric	Total	Time
3	1	1	1	
4	3		3	
5	6	2	12	
6	10		50	
7	16	4	316	
8	26		2462	
9	43	7	35,005	
10	71		710,789	1 second
11	116	12	20,359,551	20 seconds
12	188		781,232,345	21 minutes
13	304	20	3.8×10^{10}	15 hours
14	492		2.4×10^{12}	55 days
15	797		33.19×10^{14}	12 years

The columns represent the following:

Size: puzzle size

Across: number of solutions for a single row

Symmetric: number of symmetric solutions for the middle row (needed only for odd sizes)

Total: total number of solutions

Time: execution time; too small to measure below 10×10

J/F 3. Steve Jones believes that given any two rectangles of equal area, either rectangle can be cut into pieces that can be reassembled into the other rectangle. Is he right?

Several readers felt this was impossible, claiming that for irrational side lengths, no finite number of cuts would suffice. However, it appears they assumed that the cuts must be parallel to the

sides of the rectangles, which was not a stated requirement. Peter Stephens shows us how to make use of nonparallel cuts and solve the problem in general.

First, it suffices to show that any rectangle can be cut into pieces and assembled into a square. If that is possible, the process can be reversed to carve the square into any other desired rectangle. Second, we can restrict our attention to rectangles with an aspect not exceeding 2:1. (Proof: if it is greater, cut the long edge in half and stack the pieces on top of each other.

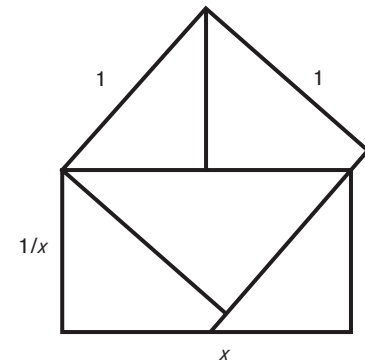

Repeat as needed.) The last step may change the rectangle's orientation from landscape to portrait or vice versa, but the ratio will still not exceed 2:1.

For simplicity, let the area be unity, so the sides are x and $1/x$, with $x \leq \sqrt{2}$. The diagram above shows a dissection into three pieces, which can be rearranged to form the desired square.

BETTER LATE THAN NEVER

2008 S/O 1. Michael Lieberman and Stephen Shalom have each found solutions with 10-trick swings.

N/D 2. F. Albusu notes that the curve traced by the end of the tether is normal to the circumference, not tangent as in the figure.

Y2008. Yacov Weiss found the following improvements: $1 = 208^0$ and $4 = 80 / 20$.

2009 J/F SD. Several readers found alternate solutions, some using base 3 arithmetic.

OTHER RESPONDERS

Responses have also been received from A. MacDonald, R. Bejar, G. Schaffer, K. Arenson, A. Sopelak, S. Jones, W. Tucker, I. Shalom, E. Sard, H. Thieriez, R. Hess, E. Signorelli, T. Turnbull, D. McMahan, J. Chandler, Z. Moledina, and A. Ucko.

PROPOSER'S SOLUTION TO SPEED PROBLEM

Two seconds. In one hour (3,600 seconds), the hand travels 1/12 a circle or 30° or 1,800 minutes of arc. ■

Send problems, solutions, and comments to Allan Gottlieb, New York University, 715 Broadway, Room 712, New York NY 10003, or to gottlieb@nyu.edu.